



HF-Regulator Intelligent Touch DALI for TL5/TL-D/PL-L lamps

HF-Ri TD 4 14/24 TL5 E+ 195-240V 50/60Hz

Tento inteligentní vysokofrekvenční elektronický předřadník pro regulaci osvětlení využívá systém DALI nebo tlačítkový protokol Touch and Dim pro zářivkové světelné zdroje. Splňuje požadavky A1BAT a reaguje tak na připravovanou legislativu. Pomocí speciálního příkazu můžete zjistit spotřebu energie ze sítě a následně zjistit, jaký je příkon připojených světelných zdrojů. V kombinaci s ovládacími prvky lze dosáhnout dalších úspor energie.

Údaje o produktu

• Obecné informace

Interface	TD
Application code	E+
Rated Lamptype	TL5
Rated Number of Lamps	4 piece
Rated Ballast-Lamp Power	14/24
Síťové napětí	195-240 V
Síťová frekvence	50/60 Hz
Housing	L 360x39x22
Index energetické efektivity	A1 BAT
Životnost - 10% selhání	50000 hr
Ignition Method	Warm Start

• Provozní údaje

Automatic restart	Yes
Ignition time	1 (max) s
Operating frequency	45 (min), 110 (max) kHz
Mains voltage safety (AC)	-10%/+10%
Mains voltage performance (AC)	-8%/+6%
Inrush current Peak	31 (max) A
Inrush current Width	0.26 ms
Earth leakage current	0.5 (max) mA
Standby power consumption	0.25 (max) W
Regulating level power	1%-100%
Ballast Lumen Factor	1.0 -
PowerFactor 100% output power	0.95 -

Battery voltage lamp ignition	198-254 V
Battery voltage running lamps	176-254
Overvoltage protection 320Vac	48 hr
Overvoltage protection 350Vac	2 hr
Control input protection	Yes (Basic insulation)
Max. počet na jistič	16 x
Stable lamp operation temp.	> 15°C
Crestfactor	1.7 (max) -
Hum and Noise level	Inaudible
Total Harmonic Distortion EUR	10 %

• Schéma zapojení

Cable-Cap output-wires to earth	200 (max) pF
Cable-Cap output-wires mutual	200 (max) pF
Conn.type input terminals	WAGO 251 universal connector [Suitable for both automatic wiring (ALF and ADS) and manual wiring]
Conn.type output terminals	WAGO 251 universal connector [Suitable for both automatic wiring (ALF and ADS) and manual wiring]
Conn.type ctrl input terminals	WAGO 251 universal connector [Suitable for both automatic wiring (ALF and ADS) and manual wiring]
Striplength	8.0-9.0 mm
Dual fixture Master/Slave	Yes [Master/Slave operation possible]

PHILIPS

HF-Regulator Intelligent Touch DALI for TL5/TL-D/PL-L lamps

Wcs Control input terminals	0.50-1.00 mm ²
Wcs Input terminals	0.50-1.00 mm ²
Wcs Output terminals	0.50-1.00 mm ²
Wcs auto insertion (ALF/ADS)	0.75 mm ²

• Údaje o řídicí jednotce

Rated Lamp Power on TL-D	18
System Power on TL-D	75
Lamp Power on TL-D	16.6
Power Loss on TL-D	8.6
Rated Lamp Power on PL-L	18/24
System Power on PL-L	70.6/100.3
Lamp Power on PL-L	15.8/22.9
Power Loss on PL-L	7.4/8.7
Rated Lamp Power on TL5	14/24
System Power on TL5	63.3/103.3
Lamp Power on TL5	14.5/23.4
Power Loss on TL5	5.3/9.7
Rated Lamp Power on TL5 ECO	13/20
System Power on TL5 ECO	55/86.9
Lamp Power on TL5 ECO	12.9/19.7
Power Loss on TL5 ECO	3.4/8.1
Rated Lamp Power on TL-D ECO	16
System Power on TL-D ECO	64.3
Power Loss on TL-D ECO	7.5
Lamp Power on TL-D ECO	14.2

• Teplotní údaje

T-case life	75 (max) C
T-case maximum	75 (max) C
T-ignition	-25 (min), 50 (max) C
T-ambient	-25 (min), 50 (max) C

T-storage	-40 (min), 80 (max) C
-----------	-----------------------

• Rozměry produktu

Length A1	360.0 mm
Fixing Hole Distance	350.0 mm
Length A2	
Width B1	39.0 mm
Height C1	22.0 mm
Fixing Hole Diameter	4.2 mm
D1	

• Aplikační charakteristika

EMI 9kHz .. 30 MHz	EN 55015
EMI 30 MHz .. 1000MHz	EN 55022 Class B
Safety Standard	IEC 61347-2-3
Performance Standard	IEC 60929
Quality Standard	ISO 9000:2000
Environmental Standard	ISO 14001
Harmonic current emissions	IEC 61000-3-2
EMC Immunity	IEC 61547
Vibrations	IEC 68-2-6 Fc
Bumps	IEC 68-2-29 Eb
Humidity	EN 61347-2-3 clause 11
Approval marks	ENEC / VDE-EMV
CE marking	Yes
Temperature marking	110 [Yes]
Emergency standard	IEC 60598-2-22

• Produktové informace

Objednávkové číslo	156789 00
Kód produktu	871829115678900
Název produktu	HF-Ri TD 4 14/24 TL5 E+ 195-240V 50/60Hz
Název objednávaného produktu N	HF-Ri TD 4 14/24 TL5 E+ 195-240V 50/60Hz
Pocet kusu v balení N	1
Balící množství	10
Pocet balení v transportním balení	10
EAN produktu	8718291156789
EAN transportního balení	8718291156796
eop_12nc	913700679166
Hmotnost produktu	0.392 kg

HF-Regulator Intelligent Touch DALI for TL5/TL-D/PL-L lamps

Rozměrové výkresy

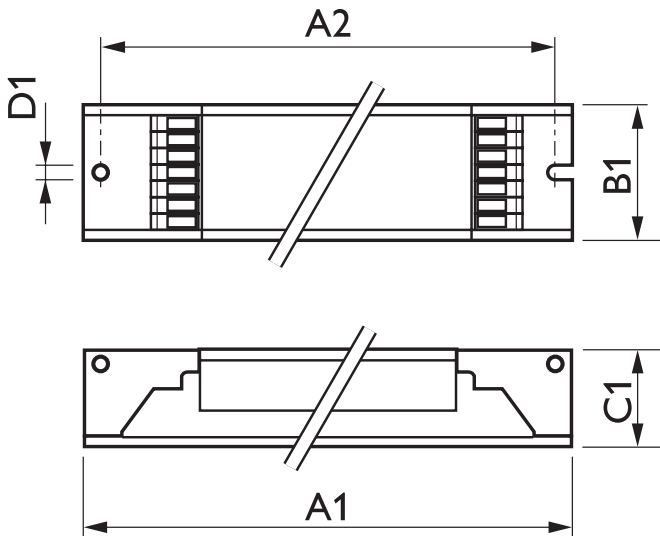

HF-Ri TD 4 14/24 TL5 E+ 195-240V 50/60Hz

Product	A1 (Norm)	A2 (Norm)	B1 (Norm)	B2 (Norm)	C1 (Norm)	D1 (Norm)
HF-Ri TD 4 14/24 TL5 E+ 195-240V 50/60Hz	360.0	350.0	39.0	-	22.0	4.2

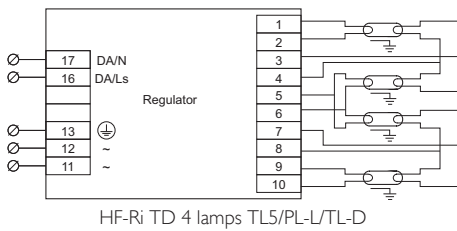

© 2014 Koninklijke Philips N.V. (Royal Philips)
Všechna práva vyhrazena

Změna specifikací bez upozornění. Ochranné známky jsou vlastnictvím Koninklijke Philips N.V. (Royal Philips) nebo jejich příslušných majitelů.

www.philips.com/lighting

2014, Březen 26
Změna údajů vyhrazena