

CorePro LEDspot LV

CoreProLEDspotLV ND 4.7-35W 840 MR16 36D



CorePro LEDspots are a perfect fit for spot lighting and deliver warm halogen-like light. They are compatible with most existing fixtures with MR16 GU5.3 holders and are designed as a retrofit replacement for halogen or incandescent spots. LEDlamps deliver huge energy savings and minimize maintenance cost.

Product data

• General Information

Cap-Base	GU5.3
Bulb Shape	MR16 [2inch/50mm]
Nominal Lifetime (Nom)	15000 h
Switching Cycle	50000X
B50L70	15000
Technical Type	4.7-35W

• Light Technical

Color Code	840 [CCT of 4000K (841)]
Beam Angle (Nom)	36 °
Luminous Intensity (Nom)	900 cd
Color Designation	Cool White (CW)
Rated Beam Angle	36 °
Correlated Color Temperature (Nom)	4000 K
Luminous Efficacy (rated) (Nom)	84.04 lm/W
Color Consistency	<6
Color Rendering Index (Nom)	80
LLMF At End Of Nominal Lifetime (Nom)	70 %
Luminous Flux In 90° Cone (Rated)	395 lm

• Operating and Electrical

Power (Rated) (Nom)	4.7 W
Lamp Current (Nom)	580 mA
Wattage Equivalent	35 W
Starting Time (Nom)	0.5 s

Warm Up Time To 60% Light (Nom)	1 s
Power Factor (Nom)	0.5
Voltage (Nom)	12 V

• Temperature

T-Case Maximum (Nom)	76 °C
----------------------	-------

• Controls and Dimming

Dimmable	No
----------	----

• Approval and Application

Energy Saving Product	Yes
Suitable For Accent Lighting	Yes
Energy Efficiency Label (EEL)	A+
Energy Consumption kWh/1000 h	6 kWh

• Product Data

Full product code	871869657945900
Order product name	CoreProLEDspotLV ND 4.7-35W 840 MR16 36D
EAN/UPC - Product	8718696579459
Order code	929001240402
Numerator - Quantity Per Pack	1
Numerator - Packs per outer box	10
Material Nr. (12NC)	929001240402

PHILIPS

CorePro LEDspot LV

Net Weight (Piece) 0.045 kg

Dimensional drawing

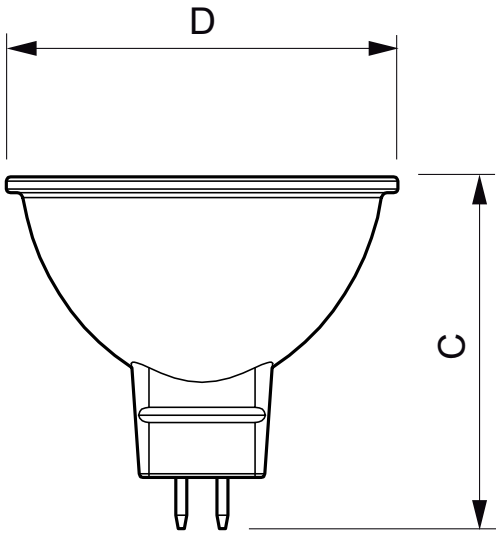

MR16 12V 5W-35W 380lm 36D 4000K GU5.3 ND

Product	D	C
CoreProLEDspotLV ND 4.7-35W 840 MR16 36D	50 mm	46 mm

Accent Lighting - Spots

MR16 4.7W4000K 36D 9290012404

435 lm(90°cone 395lm)

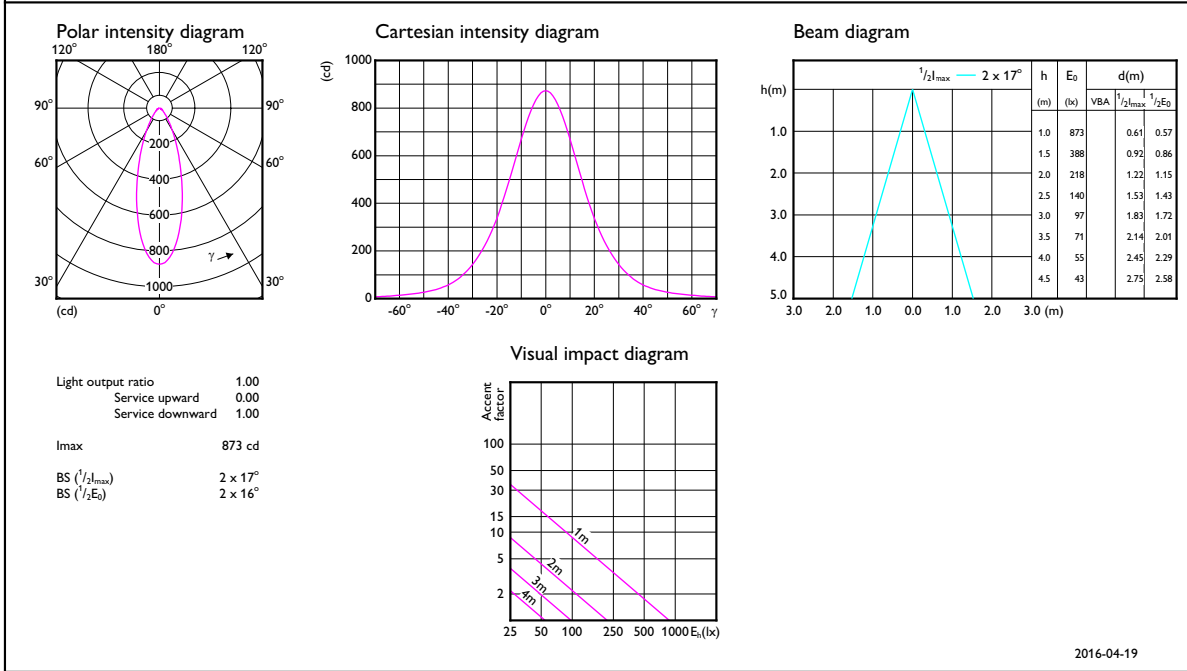

2016-04-19

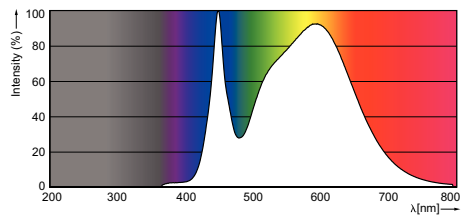

© 2016 Philips Lighting Holding B.V.
All rights reserved.

Specifications are subject to change without notice. Trademarks are the property of Koninklijke Philips N.V. (Royal Philips) or their respective owners.

www.philips.com/lighting

2016, September 16
data subject to change